

For Satellite Communication Power Amplifier Using Ku Band

^{1*}Ms. B. N. Ganthade

Dept. of E&TC, Amrutvahini Polytechnic, Sangamner

Abstract: Wireless communication systems have become ubiquitous in our daily lives. The requirements for these wireless applications vary depending on the input signal type and operating frequency. A minimum of an RF modulator, filter, mixer, power amplifier (PA), and an antenna on the transmitter side are present in the majority of wireless communication systems. In practically all wireless communication systems, the design of each of these components is essential. Which power amplifier design is the most important since the wireless system's output power is dependent on the PA's capacity to amplify low-power radio waves to the necessary level. The design, simulation, and analysis of a single-stage Ku band power amplifier based on 0.25 μ m GaN-HEMT technology are discussed in this study. An ADS schematic of the suggested PA

Keywords- GaN-HEMT technology, power amplifier, Ads, gain, output power, input power.

Date of Submission: 17-05-2026

Date of acceptance: 31-05-2026

I. INTRODUCTION

In order to make wireless systems as small and power-efficient as possible, future wireless communication systems will need to integrate multiple technologies. In order to meet the requirements of wireless systems, technologies like MEMS (micro-electromechanical systems), SoC (system on chip), and VLSI (very large scale integration) have now been merged on the same board. Depending on the operating frequency, different wireless systems have varying needs. The design of Power Amplifiers (PA) is one of the most important components in wireless systems, even if a typical wireless communication comprises multiple components, as shown in Fig. 1. As a result, the design of a PA will alter depending on the wireless application. The PA is anticipated to provide a given output power, gain, and efficiency under a given set of linearity parameters for every unique wireless application.

GaAs (gallium arsenide) technology is the basis for the long-used MMIC (monolithic microwave integrated circuits) and HIC (hybrid integrated circuits) for satellite and mobile communication applications. Nevertheless, GaAs technology has restricted output power for high input power because of its low operating voltage. On the other hand, because of its high breakdown voltage, the GaN (Gallium Nitride)-HEMT (High Electron Mobility Transistor) provides high output power. Therefore, GaN-HEMT can be employed as the power stage and a GaAs device as the driving stage. This design approach, however, is limited to HICs because MMICs prevent the integration of multiple semiconductor technologies on a single board.

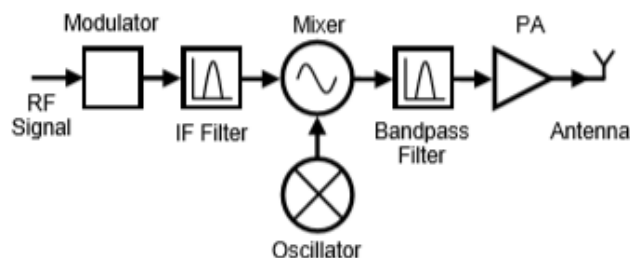

Fig. 1 Typical block diagram of wireless transmitter system

This study describes the design of a Ku band single stage power amplifier based on 0.25 μ m GaN-HEMT technology. The gain stage of the suggested PA is made to fully match input and output impedance matching for 50 Ω . ADS simulation software is used for the design simulation and analysis. Significant gain, high output power, and high PAE (Power Added Efficiency) are all achieved by the suggested PA design.

II. DESIGN METHODOLOGY

This study describes the design of a Ku band single stage power amplifier based on 0.25 μ m GaN-HEMT technology. The gain stage of the suggested PA is made to fully match input and output impedance matching for 50 Ω . ADS simulation software is used for the design simulation and analysis. Significant gain, high output power, and high PAE (Power Added Efficiency) are all achieved by the suggested PA design.

TABLE I: Design specifications of Ku band PA

Parameter	Specification
Frequency	Ku band (12 to 18 GHz)
Output power	> 40dBm
Gain	> 10dBm
PAE	> 10%

a) Bias Point selection:

Table I's design specifications state that the power amplifier needs to have a gain of roughly 10dBm and a PAE of 10%. This gives us the option to select a bias point from a large range of options. As is well known, a PA is capable of functioning in Class A, B, and AB (Table II). In order to benefit from both Class A and Class B advantages, Class AB was selected.

TABLE II: Classes of operation

Class of operation	Advantages and Disadvantages
Class A (Output current is always available)	Highest linearity and gain but has lowest efficiency (of about 50%)
Class B (Output current is available during half input signal cycle)	Higher efficiency (of about 78.5%) as compared to class A but low gain
Class AB (biased between cut off point and Class A)	Has high linearity and efficiency

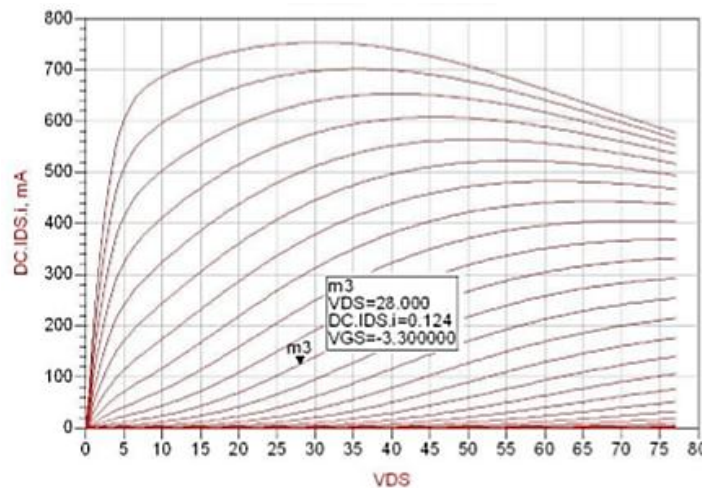

Fig. 2 IV characteristics of GaN device

The GaN device's IV characteristics are displayed in Fig. 2, providing information on how the gate and drain bias voltages can be adjusted to regulate the drain current. The bias point must be chosen between cut-off and class A for class AB operation. The gate to source voltage, $V_{GS} = -3.3V$, and the drain to source voltage, $V_{DS} = 28V$, must also be chosen

b) Stability network:

To avoid oscillations, an amplifier needs to satisfy the stability requirements, which are stability measure $|\Delta| > 0$ and stability factor $K > 1$ (close to 1). If an amplifier doesn't fit these criteria, it's considered unstable. Thus, in order to ensure the PA's unwavering stability, a stability network must be established.

Here, we have designed the stability network, which is the equivalent of a high pass filter, using a capacitor ($C6 = 0.33 \text{ pF}$) in parallel with a series resistance ($R5 = 22\Omega$) and a series resistance at the gate bias network (100Ω) (As shown in Fig. 3). This stability network should ideally pass higher frequencies while attenuating lower ones. However, because to component tolerances in PA design, using a stability network may result in a tiny drop in gain. Overall gain flatness has been supplied by the gate bias network's series resistance ($R5 = 22\Omega$). Standard film resistances are applied in all cases. We must utilize golden bonding wires to connect the single layer capacitor to the dispersed network. In series with the capacitor, a roughly approximated inductor has been added to counteract the effect of the golden connecting wires.

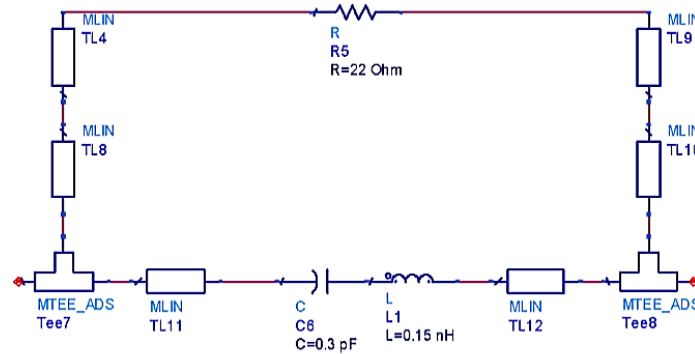

Fig. 3 Schematics of stability network

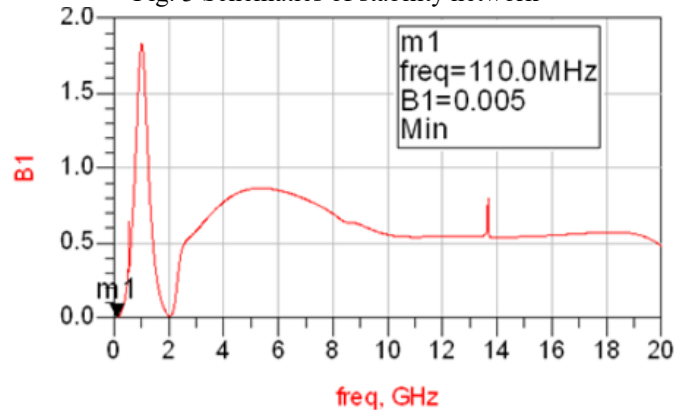

Fig. 4 Stability measure ($|\Delta|$)

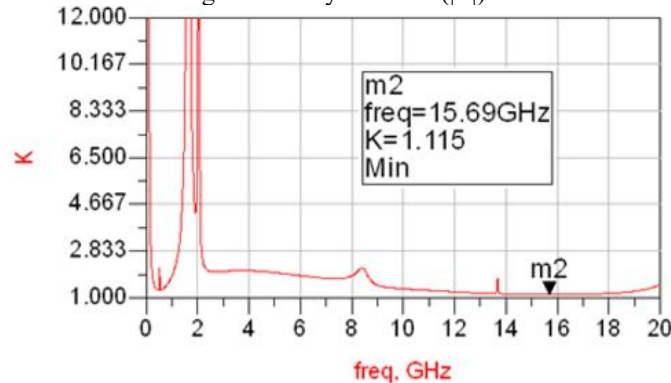

Fig. 5 Stability Factor (K)

As previously mentioned, for a PA to be considered unconditionally stable, its stability measure ($|\Delta| > 0$) and stability factor ($K > 2$). While the stability factor displayed in Fig. 5 is close to 1 for the whole Ku band frequencies, Fig. 4 demonstrates that the stability measure is greater than 0 for the whole operating Ku band.

c) **Bias network:**

The rest of the signals are transmitted through the bias network unabatedly while the undesirable DC and RF signals are blocked. By creating a bias network that functions as an open circuit at the operational frequencies, this can be accomplished. Nonetheless, particular attention must be given while taking the bias network's blocking frequency into account. Here, a quarter wave transmission line and an open radial stub are used to create an open circuit. A short transmission line is utilized between an open radial stub and a tee in order to electromagnetically define the stub. This is due to the fact that a 90° transmission line converts a short circuit to an open circuit at the device's gate, but an open radial stub becomes a short circuit at a tee junction. Fig. 6 shows schematics of the bias network.

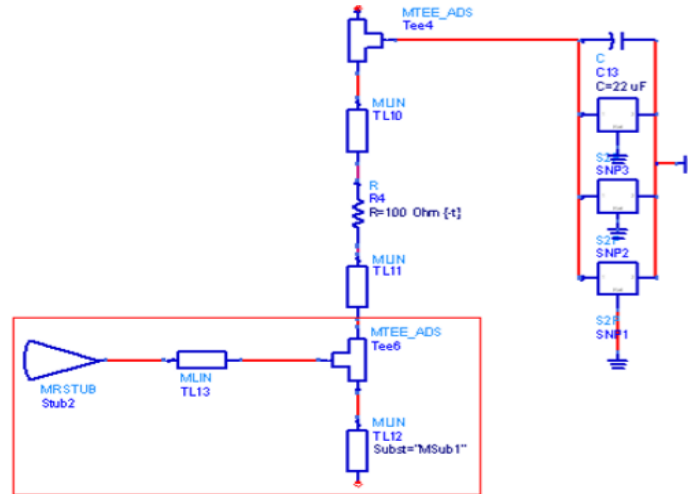

Fig. 6 Bias network schematics

d) Matching network:

A perfect match between the source and load impedances allows for the maximum power transfer theorem to be applied. The matching network converts Z_{source} (source impedance) and Z_{load} (load impedance) to standard 50Ω termination in accordance with the maximum power transfer theorem. To obtain the intended maximum power, gain, or PAE, source and load impedances must match to a standard 50Ω termination. Thus, using appropriate modeling to determine the ideal source and load impedance levels is crucial. These ideal settings are comparatively simple to determine thanks to the ADS auto tuning mechanism.

e) Gain stage amplifier design

As previously mentioned, the power stage of the PA is intended to be driven by the gain stage. The gain stage, as its name implies, is intended to supply the majority of the PA's total gain. In order to achieve high gain, source-pull and load-pull simulations are run, and a matching network based on these impedances is created. The gain, PAE, source, and load impedances of the proposed PA's gain stage are displayed in Table III.

Table III: Input and Output impedances of gain stage

Pin	Pout	Gain	PAE (%)	Z_{source}	Z_{load}
21	32.94	11.94	21.45	$0.906-j*63.38$	$5.228-j*47.49$
22	34.00	12.00	24.32	$0.906-j*63.38$	$5.228-j*47.49$
23	35.04	12.04	27.46	$0.906-j*63.38$	$5.228-j*47.49$
24	36.04	12.04	30.90	$0.906-j*63.38$	$5.228-j*47.49$
25	36.98	11.98	34.52	$0.906-j*63.38$	$5.228-j*47.49$
26	37.82	11.82	38.05	$0.906-j*63.38$	$5.228-j*47.49$
27	38.44	11.44	40.52	$0.906-j*63.38$	$5.228-j*47.49$

The gain stage's input matching network is designed to convert 50Ω transmission line impedance to $0.906-j*63.38$, the source impedance, in order to maximize power transfer. Similarly, the output matching network is designed to convert $5.228-j*47.49$, the load impedance, to 50Ω transmission line impedance..

III. RESULTS AND DISCUSSIONS

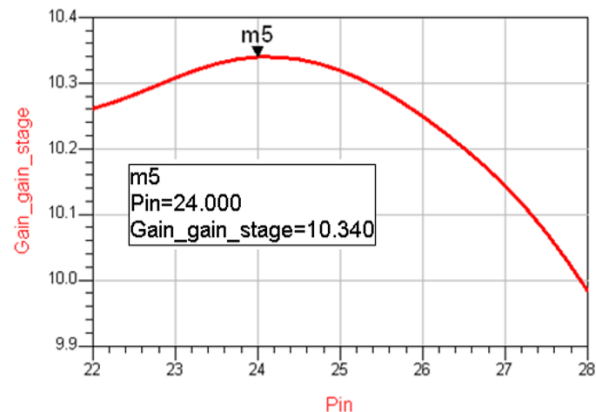

Fig. 7 Gain of the gain stage of PA

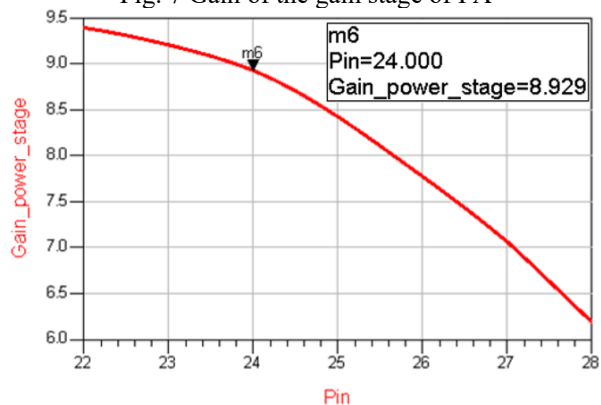

Fig. 8 Output power delivered by gain stage of PA

With an applied input of 24.00 dBm, the suggested single stage PA (the gain stage) yields an output power of 8.929 dBm and a gain of 10.340 dBm. The power amplifier will then receive the gain stage's output. As previously mentioned, the majority of the PA's total power and gain are produced by the power stage and gain stage, respectively. Therefore, following the design of the PA's second stage, or power stage, a slight but discernible difference in gain can be seen. Following the power stage's design, the final gain, efficiency, and PAE provided by the PA will be computed..

IV. CONCLUSION AND FUTURE SCOPE

This work uses ADS Keysight simulation software to construct a Ku band (12-18 GHz) amplifier based on 0.25 μ m GaN-HEMT technology. The gain stage of the suggested single-stage amplifier has a high gain of 10.34 dBm (>10 dBm according to Table I's technical specifications) and a low output power of 8.929 dBm. Therefore, we must create a power stage amplifier that satisfies the technical requirements of high output power and high PAE in the later design phase..

REFERENCES

- [1] Scappaviva, F. Cignani, R. Florian, C. Vannini, G. Filicori, F. Feudale, M., "10 Watt High Efficiency GaAs MMIC Power Amplifier for Space Applications", EuMC 2008, pp. 1429 - 1432, Oct. 2008.
- [2] Alaeldine, A. Perdriau, R. Ramdani, M. Levant, J.-L. Drissi, M., "A Direct Power Injection Model for Immunity Prediction in Integrated Circuits", IEEE Transactions on Electromagnetic Compatibility, vol. 50, issue : 1, pp. 52 - 62, Feb. 2008
- [3] A. Rasmi, A. Marzuki, A.I. Abd Rahim, M.R. Yahya, A.F.A. Mat, "A 3.5 GHz Medium Power Amplifier Using 0.15 μ m GaAs PHEMT for WiMAX Applications", Asia Pacific Microwave Conference, pp. 277 - 280, December 2009
- [4] <http://pdfserv.maxim-ic.com/en/an/AN3175.pdf>
- [5] Lai, R., Grundbacher, R., Barsky, M., Oki, A., Siddiqui, M., Pitman, B., Katz, R., Tran, P., Callejo, L., Streit, D., "Extremely High P1dB MMIC Amplifier for Ka-band Applications", GaAs IC Symposium, pp. 115 - 117, 2001.
- [6] Dong JunHong, Wang QiFeng, Xie Feng, "Design of 2.4GHz Power Amplifier used in WLAN 802.11b by pHEMT", International Conference on Future Computer and Communication, vol. 1, pp. V1.722 - V1.724, 21-24 May 2010.
- [7] Negra, R., Vogt, R., Bachtold, W., "High Power-Density Monolithic Linear X-band Power Amplifier using A Low-Cost MESFET Technology", International Microwave and Optoelectronics Conference, vol. 2, pp. 877 - 880, 2003
- [8] De-Zhong Li, Cong Wang, Wen-Cheng Huang, R. Krishna, Sung-Jin Cho, B. Shrestha, Gear Inpyo Kyung, Nam-Young Kim, "A highpower Ka-band power amplifier design based on GaAs P-HEMT technology for VSAT ODU applications", IEEE International Microwave, Antenna, Propagation and EMC Technologies for Wireless communications, pp. 20 - 23, Oct 2009.

- [9] Qi Zhang, S.A. Brown, "A Fully Monolithic 8 Watt Ku-Band High Power Amplifier", IEEE MTT-S International Microwave Symposium, vol. 2, pp. 1161 - 1164, June 2004.
- [10] C. H. Lin, H. Z. Liu, C. K. Chu, H. K. Huang, Y. H. Wang, C. C. Liu, C. H. Chang, C. L. Wu, C. S. Chang, "A Fully Matched Ku-band 9W PHEMT MMIC High Power Amplifier", Compound Semiconductor Integrated Circuit Symposium, pp. 165 - 168, Nov 2006.
- [11] K. Fujii, H. Morkner, "Single-Supply 1W Ku-Band Power Amplifier Based on 0.25 μm E-Mode PHEMTs", IEEE MTT-S International Microwave Symposium, pp. 1855 - 1858, June 2006
- [12] Jia-You Song, Zhi-Gong Wang, Zhi-Qun Li, Yan-Jun Peng, Qin Li, "Ku-band Broadband Power Amplifier Designed in 0.2 μm GaAs PHEMT Process", International conference on Microwave and Millimeter Wave Technology, pp. 1-3, Apr. 2007
- [13] Mei-Chen Chuang; Pei-Si Wu; Ming-Fong Lei; Huei Wang; Yu-Chi Wang; Chan Shin Wu, "A miniature 15-50-GHz medium power amplifier", Radio Frequency Integrated Circuits Symposium, pp. - 7, June 2006.